

SUCTION-TYPE SEWER SCAVENGER



Main Parameters

Items		FLM5070GXWQ6	FLM5120GXWDF6	FLM5180GXWDF6
GVW	kg	7300	12490	18000
Wheelbase	mm	3360	3800	5000
Payload Weight	kg	3160	4685	7405
Upper Weight	kg	1860	2810	4500
Selectable Of Chassis Brand		ISUZU/DONGFENG	DONGFENG	DONGFENG
Vacuum Pump Model		50QZXDG-45/400	65QZXDG-68/400	65QZXDG-110/5000
Theoretical Pumping Speed	m ³ /min	2.7	4.08	13.2
Full Suction Time	min	≤4	≤6	≤8
Effective Suction	m	≥6	≥6	≥6
Sewage Tank Effective Volume	m ³	4.1	6.14	9.71
Sewage Tank Lifting Angle		≥45°	≥45°	≥45°
Suction Pipe Path Size	mm	110	110	110

Technical Specification

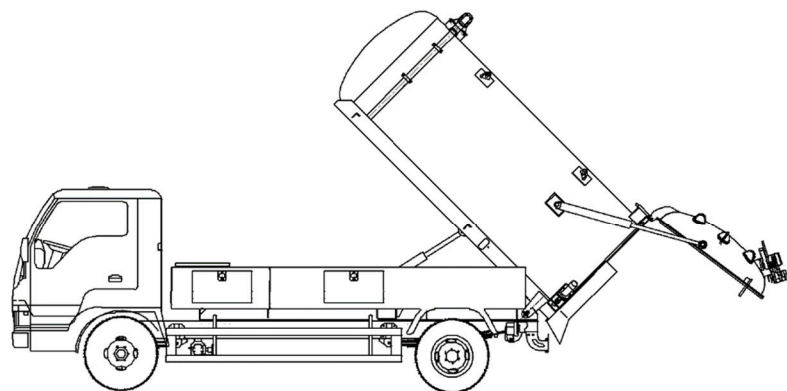
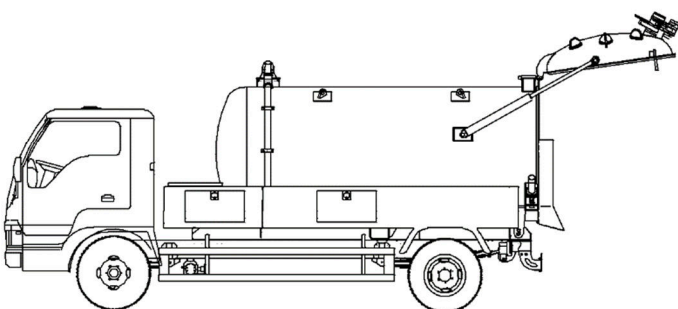

Base Specification

Vacuum pump:

- With famous brand vacuum pump, it has high absolute working pressure, large flow, large suction and long suction range.

Other function:

- The whole vehicle is equipped with wear-resistant suction pipe. The suction pipe can be connected by quick joint according to the actual needs, which not only optimizes the pipeline layout, but also makes the whole vehicle more beautiful.
- The utility model integrates the functions of sewage suction, sewage rotary filtration and self-discharge, reduces the number of vehicle round trips, reduces the labor intensity of the operators, improves the working efficiency and saves the cost.
- The inlet valve is adopted at the drain outlet to ensure the long-term tightness of the drain valve.
- FLM5180GXWDF6 rotary boom has the functions of lifting, rotating and stretching. It has a wide range of coverage and strong mobility. It is equipped with a remote control and night work lights. It is easy to use and has high efficiency.
- FLM5120GXWDF6 manually rotate the suction arm to enlarge the suction area, so that the suction range is wider and the use is more labor-saving, and the detachable splicing suction pipe is used.

Liquid level display device:

- The liquid level display of sewage tank adopts the imported liquid level display device, which is easy to observe, disassemble, clean and maintain.

Body:

- The car adopts round tank, which has good pressure bearing performance and technical performance index reaching or even surpassing that of similar domestic products. It is mainly used for suction and transportation of sludge, feces or sediment in sewage, rainwater well, septic tank and various ditches.

Rear door locking mechanism:

- The rear door adopts the independent patent environmental sanitation tank type special vehicle back door opening and locking device, hydraulic system with safety protection, and double safety mechanism to make the garbage box and the back door rubber strip reliably sealed, so as to ensure that the sewage is in a closed state in the collection and

Optional device:

- Optional stainless steel tank.
- FLM5070GXWQ6:
 1. Imported vacuum pump.
 2. Manual suction lifting arm.
- FLM5120GXWDF6:
 1. Cleaning system
 2. Imported vacuum pump
- FLM5180GXWDF6:
 1. Without cleaning system.